

Survey on the Societas Europaea  
September 2003

**Annex 4 - Finland**

# FINLAND

*Overview*

Until now, the Finnish tax law does not include any provisions that would expressly mention Societas Europaea (SE). Based on Art. 9(1)(c) of the EC regulation on the Statute for a European company (2157/2001), Finland should treat an SE which has its registered office in Finland the same way as Finland treats Finnish public limited companies (*julkinen osakeyhtiö; Oyj*). Because of the lack on any express rules on the tax treatment of SEs, the tax treatment of an SE that has its registered office in Finland depends at the moment on the existing Finnish domestic law rules, the tax treaties completed by Finland, the relevant provisions of the EC Treaty and the few EC Directives having relevance on direct tax matters. Even the EC tax Directives apply to SEs only after SEs are expressly included in the Directives. For example, the Finnish domestic law rules of the Business Income Tax Act (EVL § 52-52g) implementing the EC Merger Directive (90/434/EEC) must be applied to SEs, provided SEs are included in the Merger Directive. The same applies to the Finnish domestic law rules implementing the EC Parent-subsidiary Directive (90/435/EEC).<sup>1</sup>

Based on Section 3 of the Finnish Income Tax Act (TVL), it is clear that an SE will be treated as a corporate body (*yhteisö*) for tax purposes in Finland. It is an entity, which is comparable to the Finnish entity forms treated as separate tax subjects in Finland. Therefore, also an SE will be treated as such, even though SEs are not expressly mentioned in TVL § 3.

Most Finnish tax law rules refer to corporate bodies, without specifying, which corporate bodies are covered. These rules will automatically apply to SEs. It is also likely that the rules that refer to a Finnish corporate body will be applied to an SE with its registered office in Finland, even though SEs would not expressly be added to the provisions. Some rules, however, refer expressly only to the Finnish *osakeyhtiö* (Finnish limited companies). It is unclear whether also these rules will be applied to an SE with its registered office in Finland unless SEs will be expressly added to the provisions. If the rules are applied strictly by their wording, they do not apply to SEs. In some cases, however, it may be possible that the rules will be applied by analogy also to SEs. It may also be imagined, that in some cases for example the non-discrimination article or for example the four basic freedoms of the EC Treaty may be said to require that the domestic law rules be applied to SEs. In any case, for the sake of clarity, it is recommended that these rules be amended expressly to cover also an SE with its registered office in Finland.

*The Finnish Rules Implementing the EC Merger Directive*

The requirements of the EC Merger Directive are implemented in Sections 52–52g of the Finnish Business Income Tax Act. The same provisions, excluding the ones concerning

---

<sup>1</sup> EVL § 6(2), TVL § 53(1)(7) (Income Tax Act), *Lähdeverolaki* § 3(5) (Act on Taxation of Income and Capital of a Person Subject to Limited Tax Liability).

transfers of assets, are applicable also for the purposes of taxation carried out in accordance with the Income Tax Act.<sup>2</sup>

The same Finnish domestic law provisions apply to both pure domestic arrangements and to arrangements involving a company of another EU Member State.<sup>3</sup> A company is regarded to be from a EU Member State, if the company is considered to be a resident in a Member State according to the domestic tax laws of that state. It is also required that the company is not considered to be a resident of a state, which is not a Member State, for the purposes of a tax treaty concluded with such a state.<sup>4</sup>

The special treatment covers only arrangements involving companies, which take one of the forms listed in the Annex of the directive and which are subject to one of the corporate taxes listed in the Directive, without the possibility of an option or of being exempt.<sup>5</sup> SEs are thus covered provided that they are included in the Annex.

#### *Cases 1-2 (Merger)*

The Finnish domestic law provisions on mergers are included in EVL §§ 52a and 52b and TVL § 28. The same provisions apply to domestic mergers and mergers involving a company from another EU Member State.<sup>6</sup>

The special provisions apply to mergers in which one or more Finnish corporate bodies or business partnerships are dissolved without liquidation and all of the assets and liabilities of the dissolved company are transferred to another Finnish corporate body or business partnership. The parties of a merger may be also such companies from other EU Member States, which are covered by the Merger Directive and are liable to pay corporate taxes mentioned in the Directive. The shareholders of the dissolved company, which may be residents or non-residents, must receive shares in the receiving company as compensation in proportion to their shareholding. A small part of the compensation, corresponding to 10 per cent of the nominal value of the shares received as compensation at the most, may consist of a cash payment.<sup>7</sup>

A merger covered by the special provisions does not cause any direct tax consequences to the companies or their shareholders in Finland.<sup>8</sup>

The Finnish tax law includes also special rules (TVL § 24 § and EVL § 51c) allowing the transformation of different Finnish entity forms to another Finnish entity form. A transformation may be carried out without the transformed company to be dissolved for tax purposes and consequently without any direct tax consequences. According to TVL § 24(1)(6), the same tax treatment is applicable in any situation, that is comparable to the

---

<sup>2</sup> TVL §§ 28 and 45(2).

<sup>3</sup> EVL §§ 52(2) and 52e.

<sup>4</sup> EVL § 52(2).

<sup>5</sup> EVL § 52(2) and Article 3(a) of the Directive

<sup>6</sup> EVL §§ 52(2) and 52e.

<sup>7</sup> EVL §§ 52 and 52a.

<sup>8</sup> EVL § 52b.

situations expressly covered by the special rules. Therefore, there is no obstacle to apply the same treatment also, when a limited liability company is transformed to an SE. However, before some actual cases exist or SEs will be expressly included in TVL § 24, it is not totally certain whether this would be the interpretation of the Finnish tax authorities and the Finnish tax courts. Therefore, the best would be to include a transformation of a limited liability company expressly in TVL § 24. If the special rules are not regarded to apply, the transformed company is regarded to dissolve for tax purposes and the assets are regarded to have been transferred for current values.<sup>9</sup>

---

<sup>9</sup> TVL § 27 and EVL § 51d.

## CASE 1

### *Merger by acquisition*

(Art. 2 par. 1 jo. Art 17 par. 2(a) Reg. 2157/2001)

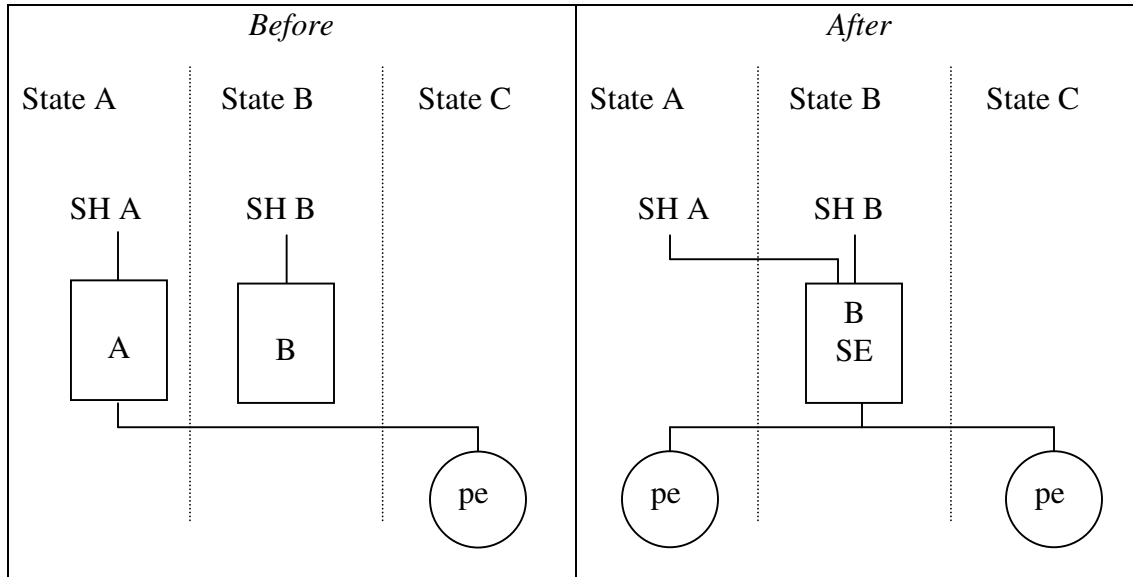

### Facts and assumptions

- SH = shareholder(s), resident in the respective country in which SH is situated
- A and B are existing companies
- A and B are public limited-liability companies (see Annex I to Reg. 2157/2001)
- State A, State B, and State C are EU Member States
- A:
  - formed under law of Member State A
  - registered office in Member State A
  - head office in Member State A
  - has a permanent establishment in Member State C
- B:
  - formed under law of Member State B
  - registered office in Member State B
  - head office in Member State B
- B SE:
  - registered office in Member State B
  - head office in Member State B
  - will be covered by the EC Merger Directive

### Transactions

- A:
  - transfers all assets and liabilities to B

- in exchange for shares in B (and cash payment if any, not exceeding 10% of nominal value of shares to be issued) issued to shareholder(s) of A
- will be wound up without going into liquidation
  
- B / B SE:
  - as the acquiring company, B will take the form of an SE when the merger takes place (Art. 17 Reg. 2157/2001: “In the case of a merger by acquisition, the acquiring company shall take the form of an SE when the merger takes place”. Consequently, there are in fact two transactions: 1) the merger and 2) a transformation of a public limited-liability company into an SE. With regard to the transformation, see also Case 9.)
  - will be regarded as public limited-liability company governed by law of Member State B

## Questions

*It is most likely that a merger by acquisition as described in Case 1 will be looked at as two separate transactions in Finland: a merger of A to B and a transformation of B to B SE. The answers to the following questions are based on this assumption. It is, however, possible that the merger would be viewed as one single transaction of A merging to B SE. If this would be the interpretation, then the following answers regarding the merger of A to B would be applicable to the whole set of transactions.*

- 1) Member State A is Finland

### Tax effects for A (the Finnish transferring company) in A (Finland)

*The Finnish transferring company (A) is not deemed to dissolve for tax purposes when it is merged to B. In principle, the loss resulting from a merger is not deductible expense and a gain is not taxable income. No capital gains will be taxed as long as the transferred assets remain connected with a permanent establishment in Finland.<sup>10</sup> If the assets do not remain in a permanent establishment in Finland, the current value of the assets is taxable income in Finland.<sup>11</sup>*

*A special provision applies because the assets, transferred in a merger of a Finnish company (A) to a company of another EU Member State (B), were connected with a permanent establishment of the Finnish company in another EU Member State (C).<sup>12</sup> Accordingly the current value of the transferred assets is included in taxable income of the Finnish transferring company (A). The tax, which the company would have paid in the permanent establishment state (C) for the same income, if the Merger Directive had not applied, is deducted from the tax in Finland. The income may also be totally tax-*

---

<sup>10</sup> EVL § 52e(1).

<sup>11</sup> EVL § 52e(2).

<sup>12</sup> EVL § 52e(3).

*exempt if an applicable tax treaty requires Finland to apply the exemption method with respect to permanent establishments.*

- a) Will the merger give rise to any taxation of capital gains (= real value of assets & liabilities transferred minus their value for tax purposes) for A, or is there roll-over relief?

*The merger of A to B does not cause any capital gains taxation except with respect to the assets that were connected with the permanent establishment in State C. The current value of these transferred assets is included in taxable income of the Finnish transferring company.<sup>13</sup>*

*The transformation of B to B SE should not have any tax consequences to A, which does not exist then anymore.*

- b) May provisions and reserves, which are partly or wholly exempt from tax and which are not derived from permanent establishments outside Member State A, be taken over with the same roll-over relief by the permanent establishment of B SE in Member State A?

*According to EVL § 52b(2) provisions and reserves may be used in the receiving company B the same way as they would have been used in the distributing company A. There are no special provisions about the treatment of these items in the case of a receiving foreign company with a permanent establishment in Finland. Based on the general rules on permanent establishments, the tax treatment of a permanent establishment of a company from another Member State should be the same as the tax treatment of a Finnish company. The permanent establishment of B in Finland can thus take over any provisions and reserves.*

*The provisions and reserves may instead be lost when B is transformed to B SE. The Finnish law is not clear in this respect. The Finnish tax law includes special rules (TVL § 24 § and EVL § 51c) allowing the transformation of different Finnish entity forms to another Finnish entity form. A transformation may be carried out without the transformed company to be dissolved for tax purposes and consequently without any direct tax consequences. According to TVL § 24(1)(6), the same tax treatment is applicable in any situation, that is comparable to the situations expressly covered by the special rules. Therefore, there is no obstacle to apply the same treatment also, when a limited liability company is transformed to an SE. However, before some actual cases exist or SEs will be expressly included in TVL § 24, it is not totally certain whether this would be the interpretation of the Finnish tax authorities and the Finnish tax courts. If the special rules are not regarded to apply, the transformed company is regarded to dissolve for tax purposes and the assets are regarded to have been transferred for current values.<sup>14</sup> If B is regarded to be dissolved, also the provisions and reserves are lost.*

---

<sup>13</sup> EVL § 52b.

<sup>14</sup> TVL § 27 and EVL § 51d.

- c) Will B's permanent establishment in Member State A be allowed to take over the losses of A that have not been exhausted for tax purposes? If B would be a company resident in Member State A, would it then be allowed to take over these losses?

*According to EVL § 52b the expenses and costs of the transferring company A are deductible within the recipient company B the same way as they would have been deducted in the transferring company A. The maximum depreciations for the year of the merger of the recipient company are decreased by the amount of depreciations allowed in the taxation of the transferring company for the same tax year. The loss resulting from a merger is not deductible expense and a gain is not taxable income.*

*Possible losses that have not yet been exhausted and unused imputation credits, tax excesses or dividend excesses of the transferring company A may be used in receiving company B, provided that the company (B) or its shareholders held over 50 % of the shares of the transferring company (A) from the moment from which the losses or the other items originate.<sup>15</sup> There are no special provisions about the treatment of these items in the case of a receiving foreign company with a permanent establishment in Finland. Based on the general rules on permanent establishments the tax treatment of a permanent establishment of a company from another Member State should be the same as the tax treatment of a Finnish company.*

*The same way as with respect to any reserves, the unused losses may be lost when B is transformed to B SE. The losses will be lost, if the special rules of TVL § 24 § and EVL § 51c are not regarded to apply (See the answer to question b).*

- d) and e) Will Member State A renounce any right to tax the permanent establishment in Member State C? Or will Member State A tax profits or capital gains with respect to the permanent establishment as a result of the merger? If so, will Member State A give relief for any (notional) tax charged on these profits or capital gains by Member State C?

*The current value of the assets that were connected with the permanent establishment in State C is included in taxable income of the Finnish transferring company in the tax year of the reorganization. The tax, which the company would have paid in the permanent establishment State C for the same income, if the Merger Directive had not applied, is deducted from the tax in Finland. The income may also be totally tax-exempt if an applicable tax treaty requires Finland to apply the exemption method with respect to permanent establishments. After the reorganization, Finland will not tax the profits connected with the permanent establishment in State C.*

- f) Will Member State A reinstate in the taxable profits of A such losses of the permanent establishment as have been set off against the taxable profits of A in Member State A and which have not been recovered at the time of the merger?

---

<sup>15</sup> TVL §§ 122 and 123 and YHL §§ 5a, 6d and 10.



*There will be no reinstating.*

Tax effects for SH A (Finnish resident shareholder of the Finnish transferring company) in Member State A (Finland)

*g) Will the issue of shares by B SE to SH A, resident in Member State A, in exchange for shares in A give rise to any taxation of the income, profits or capital gains of that shareholder?*

*According to EVL § 52b the exchange of the shares in the transferring company (A) for shares in the recipient company (B) is not treated as a taxable event for the shareholders. The deductible acquisition cost of the shares, which were received as a consideration, is equal to the acquisition cost of the shares in the transferring company. The possible cash payment used for consideration instead is subject to the capital gains treatment.*

*Instead, the transformation of B to B SE may have tax consequences. If the special rules of TVL § 24 § and EVL § 51c are not regarded to apply the transformation is treated as a liquidation of B and SH A will then be regarded to receive a taxable liquidation distribution (or liquidation loss).<sup>16</sup>*

*h) Will the issue of shares by B SE to a shareholder of A, not resident in Member State A, in exchange for shares in A give rise to any taxation of the income, profits or capital gains of that shareholder?*

*EVL § 52b does not require that the shareholders be Finnish residents, but the provision applies the same way to Finnish and non-resident shareholders. The exchange of the shares in the transferring company A for shares in the recipient company B is not treated as a taxable event for the non-resident shareholders. The deductible acquisition cost of the shares, which were received as a consideration, is equal to the acquisition cost of the shares in the transferring company. The possible cash payment used for consideration instead is subject to the capital gains treatment. Non-residents, however, are not liable to pay any taxes for capital gains on movable property in Finland, unless the capital gain is connected with a permanent establishment in Finland.*

*The transformation of B to B SE may in principle be treated as a taxable transaction. If the special rules of TVL § 24 § and EVL § 51c are not regarded to apply the transformation is treated as a liquidation of B and the non-resident shareholder will then be regarded to receive a taxable liquidation distribution (or liquidation loss).<sup>17</sup> Non-residents, however, are not taxed for capital gains from movable property, unless the gain is connected with a permanent establishment in Finland.*

*i) Will the answers to the questions 1g) and 1h) differ if SH A is:*

*i) A corporate shareholder?*

*No difference.*

---

<sup>16</sup> TVL § 27 and EVL § 51d.

<sup>17</sup> TVL § 27 and EVL § 51d.

- ii) An individual shareholder not owning a substantial interest?  
*No difference.*
- iii) An individual shareholder owning a substantial interest?  
*No difference.*
- iv) An individual entrepreneur?  
*No difference.*

2) Member State B is Finland

Tax effects for B (the Finnish receiving company) and B SE in Member State B (Finland)

- a) According to Art. 17 par. 2 Reg. 2157/2001, the acquiring company shall take the form of an SE when the merger takes place. According to Art. 37 par. 2 Reg. 2157/2001 the conversion of a public limited-liability company into an SE shall not result in the winding up of the company or in the creation of a new legal person. However, the Regulation itself does not give guidance with regard to taxation. Will the fact that B takes the form of an SE have corporate income tax consequences in Member State B?

*The transferring company (A) is not deemed to dissolve for tax purposes. According to EVL § 52b the expenses and costs of the transferring company (A) are deducted within the recipient company (B) as they would have been deducted in the transferring company. The maximum depreciations for the year of the merger of the recipient company are decreased by the amount of depreciations allowed in the taxation of the transferring company for the same tax year. The loss resulting from a merger is not deductible expense and a gain is not taxable income.*

*Possible non-deducted losses of the transferring company (A) may be used in the receiving company (B), provided that the company (B) or its shareholders held over 50 % of the shares of the transferring company from the moment from which the items originate.<sup>18</sup>*

*Finnish tax law includes special rules (TVL § 24 § and EVL § 51c) allowing the transformation of different Finnish entity forms to another Finnish entity form. A transformation may be carried out without the transformed company to be dissolved for tax purposes and consequently without any direct tax consequences. According to TVL § 24(1)(6), the same tax treatment is applicable in any situation, that is comparable to the situations expressly covered by the special rules. Therefore, there is no obstacle to apply the same treatment also, when a limited liability company (B) is transformed to an SE (B SE). However, before some actual cases exist it is not totally certain whether this would be the interpretation of the Finnish tax authorities and the Finnish tax courts. If the special rules are not regarded to apply to the transformation, B is regarded to dissolve*

---

<sup>18</sup> TVL §§ 122 and 123.

*for tax purposes and its assets are regarded to be transferred for current values leading to capital gains tax treatment.<sup>19</sup>*

- b) What is the value for tax purposes that B SE has to attribute to the assets and liabilities, which are transferred to B SE as part of the merger and that form a permanent establishment in Member States A and C?

*All assets and liabilities get the same value in the receiving company B as they had in the books of the distributing company (A) at the moment of the reorganisation.<sup>20</sup> The transformation of the receiving company B to the B SE, however, is possible without any direct tax consequences only if the special rule of TVL § 24 and EVL § 51c are regarded to apply. If this is the case, all assets and liabilities are transferred in their book values.<sup>21</sup> If TVL § 24 and EVL § 51c instead is not regarded to be apply the assets are regarded to have been transferred for their current values.<sup>22</sup>*

#### Tax effects for SH B in Member State B

- c) Will the fact that B will take the form of an SE result in tax consequences for SH B?

*The transformation will have no tax consequences, provided that the Finnish special tax law rules (TVL § 24 § and EVL § 51c) will be interpreted to cover also a transformation to an SE. If the special rules, instead, are not regarded to cover a transformation to an SE, the transformation will be taxed as a liquidation of company B leading to taxable liquidation distribution (or liquidation loss) to the shareholder.<sup>23</sup>*

- d) Will the answer to question 2c) above differ if SH B is:
- i) A corporate shareholder?  
*No.*
  - ii) An individual shareholder not owning a substantial interest?  
*No.*
  - iii) An individual shareholder owning a substantial interest?  
*No.*
  - iv) An individual entrepreneur?  
*No.*

### 3) Member State C is Finland

#### Tax effects for A and B SE in Member State C (Finland) with respect to its permanent establishment in Member State C (Finland)

---

<sup>19</sup> TVL § 27 and EVL § 51d.

<sup>20</sup> EVL § 52b.

<sup>21</sup> TVL § 24.

<sup>22</sup> TVL § 27 and EVL § 51d.

<sup>23</sup> TVL § 27 and EVL § 51d.

- a) Will the merger give rise to any taxation in A of capital gains (= real value of assets & liabilities transferred minus their value for tax purposes) or is there roll-over relief?

*The merger gives rise to taxation for A in Finland only if the property connected with the permanent establishment in Finland is transferred abroad. Such transfer is treated as an alienation for Finnish tax purpose. The current value of the transferred property is included in the taxable profits of the permanent establishment.<sup>24</sup>*

*The transformation of B to BE SE, instead, may have tax consequences if the Finnish special tax law rules of TVL § 24 § and EVL § 51c are not regarded to apply to the transformation. Then B is regarded to dissolve for tax purposes and the assets are regarded to have been transferred for their current values.<sup>25</sup> This treatment, however, does not have effect on A, which does not exist anymore at the moment of the transformation.*

- b) May provisions and reserves, which are partly or wholly exempt from tax and which are not derived from permanent establishments outside Member State C, be taken over with the same roll-over relief by the permanent establishment of B SE in Member State C?

*According to EVL § 52b(2) provisions and reserves of A may be used in the receiving company B the same way as they would have been used in the distributing company A. The transformation of B to BE SE, instead, includes that the provisions and reserves are lost if the Finnish special tax law rules of TVL § 24 § and EVL § 51c are not regarded to apply to the transformation. Then B is regarded to dissolve for tax purposes.<sup>26</sup>*

- c) Will B SE's permanent establishment in Member State C be allowed to take over the losses of A's permanent establishment that have not been exhausted for tax purposes?

*Possible losses of the transferring company A, which have not yet been exhausted may be used in receiving company B, provided that the company (B) or its shareholders held over 50 % of the shares of the transferring company (A) from the moment from which the items originate.<sup>27</sup> The transformation of B to BE SE, instead, may include that the losses will be lost if the Finnish special tax law rules of TVL § 24 § and EVL § 51c are not regarded to apply to the transformation. Then B is regarded to dissolve for tax purposes.<sup>28</sup>*

- d) If B SE would be a company resident in Member State C, would it then be allowed to take over these losses? See Merger Directive Art. 6.

---

<sup>24</sup> EVL § 51e.

<sup>25</sup> TVL § 27 and EVL § 51d.

<sup>26</sup> TVL § 27 and EVL § 51d.

<sup>27</sup> TVL §§ 122 and 123.

<sup>28</sup> TVL § 27 and EVL § 51d.

*No difference.*

## CASE 2

### *Merger by formation of a new company* (Art. 2 par. 1 jo Art 17. par 2(b) Reg. 2157/2001)

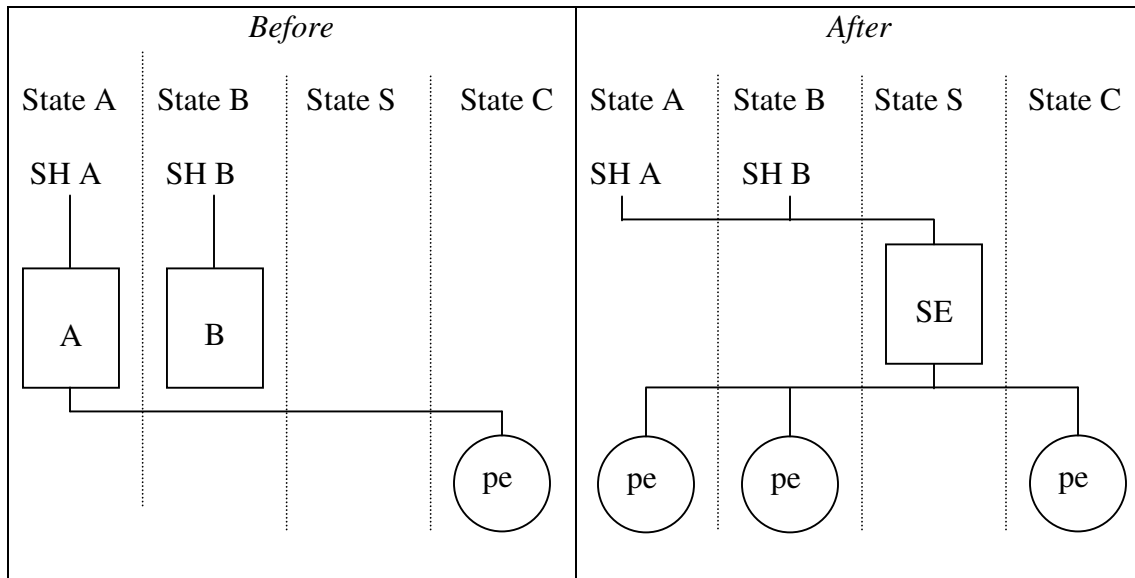

#### Facts and assumptions

- SH = shareholder(s), resident in the respective country in which SH is situated
- A and B are existing companies
- A has a permanent establishment in Member State C
- SE is a new company in State S
- A and B are public limited-liability companies (see Annex I to Reg. 2157/2001)
- State A, State B, State C, and State S are EU Member States
- A:
  - formed under law of Member State A
  - registered office in Member State A
  - head office in Member State A
- B:
  - formed under law of Member State B
  - registered office in Member State B
  - head office in Member State B
- SE:
  - formed under law of Member State S
  - registered office in Member State S
  - head office in Member State S
  - will be covered by the EC Merger Directive

### **Transactions**

- A:
  - transfers all assets and liabilities to SE
  - in exchange for shares of SE (and cash payment if any, not exceeding 10% of nominal value of shares to be issued) issued to shareholder(s) of A
  - will be wound up without going into liquidation
- B:
  - transfers all assets and liabilities to SE
  - in exchange for shares of SE (and cash payment if any, not exceeding 10% of nominal value of shares to be issued) issued to shareholder(s) of B
  - will be wound up without going into liquidation
- SE:
  - will be a newly formed SE
  - will be regarded as public limited-liability company governed by the law of Member State S

### **Questions**

1) Assume Member State A is Finland

#### Tax effects for A in Member State A (Finland)

*The Finnish transferring company (A) is not deemed to dissolve for tax purposes. In principle, the loss resulting from a merger is not deductible expense and a gain is not taxable income. No capital gains will be taxed as long as the transferred assets remain connected with a permanent establishment in Finland.<sup>29</sup> If the assets do not remain in a permanent establishment in Finland, the current value of the assets is taxable income in Finland.<sup>30</sup>*

*However, a special provision applies because the assets, transferred in a merger of a Finnish company (A) to a company of another EU Member State (S), were connected with a permanent establishment of the Finnish company in another EU Member State (C).<sup>31</sup> Accordingly the current value of the transferred assets is included in taxable income of the Finnish transferring company (A). The tax, which the company would have paid in the permanent establishment state(C) for the same income, if the Merger Directive had not applied, is deducted from the tax in Finland. The income may also be totally tax-exempt if an applicable tax treaty requires Finland to apply the exemption method with respect to permanent establishments.*

- a) Will the merger give rise to any taxation of capital gains (= real value of assets & liabilities transferred minus their value for tax purposes), or is there rollover relief?

---

<sup>29</sup> EVL § 52e(1).

<sup>30</sup> EVL § 52e(2).

<sup>31</sup> EVL § 52e(3).

*There is no capital gains taxation except with respect to the assets that were connected with the permanent establishment in State C. The current value of these transferred assets is included in taxable income of the Finnish transferring company.*

- b) May provisions and reserves, which are partly or wholly exempt from tax and which are not derived from permanent establishments outside Member State A, be taken over with the same roll-over relief by the permanent establishment of SE in Member State A?

*According to EVL § 52b(2) provisions and reserves may be used in the receiving company the same way as they would have been used in the distributing company A. There are no special provisions about the treatment of these items in the case of a receiving foreign company with a permanent establishment in Finland. However, based on the general rules on permanent establishments the tax treatment of a permanent establishment of a company from another Member State should be the same as the tax treatment of a Finnish company.*

- c) Will SE's permanent establishment in Member State A be allowed to take over the losses of A that have not been exhausted for tax purposes? If SE would be a company resident in Member State A, would it then be allowed to take over these losses?

*According to EVL § 52b the expenses and costs of the transferring company are deductible within the recipient company the same way as they would have been deducted in the transferring company. The maximum depreciations for the year of the merger of the recipient company are decreased by the amount of depreciations allowed in the taxation of the transferring company for the same tax year. The loss resulting from a merger is not deductible expense and a gain is not taxable income.*

*Possible losses of A that have not yet been exhausted and unused imputation credits, tax excesses or dividend excesses of the transferring company (A) may be used in the receiving company (SE), provided that the company (SE) or its shareholders held over 50 % of the shares of the transferring company (A) from the moment from which the items originate.<sup>32</sup> There are no special provisions about the treatment of these items in the case of a receiving foreign company with a permanent establishment in Finland. However, based on the general rules on permanent establishments the tax treatment of a permanent establishment of a company from another Member State should be the same as the tax treatment of a Finnish company.*

- d) and f) Will Member State A renounce any right to tax the permanent establishment in Member State C? Or will Member State A tax profits or capital gains of the permanent establishment resulting from the merger? If so, will it give relief for any (notional) tax charged on these profits or capital gains by Member State C?

---

<sup>32</sup> TVL §§ 122 and 123 and YHL §§ 5a, 6d and 10.



*The current value of the assets that were connected with the permanent establishment in State C is included in taxable income of the Finnish transferring company A in the tax year of the reorganization. The tax, which the company would have paid in the permanent establishment State C for the same income, if the Merger Directive had not applied, is deducted from the tax in Finland. The income may also be totally tax-exempt if an applicable tax treaty requires Finland to apply the exemption method with respect to permanent establishments. After the reorganization and the described tax consequences, Finland will not tax the profits connected with the permanent establishment in State C.*

- e) Will Member State A reinstate in the taxable profits of A such losses of the permanent establishment as have been set off against the taxable profits of A in Member State A and which have not been recovered at the time of the merger?

*There will be no reinstating.*

Tax effects for SH A in Member State A (Finland)

- g) Will the issue of shares by SE to SH A, resident in Member State A, in exchange for the shares in A give rise to any taxation of the income, profits or capital gains of that shareholder or is there roll-over relief?

*According to EVL § 52b the exchange of the shares in the transferring company for shares in the recipient company is not treated as a taxable event for the shareholders. The deductible acquisition cost of the shares, which were received as a consideration, is equal to the acquisition cost of the shares in the transferring company. The possible cash payment used for consideration instead is subject to the capital gains treatment.*

- h) Will the issue of shares by SE to a shareholder of A, not resident in Member State A, in exchange for the shares in A give rise to any taxation of the income, profits or capital gains of that shareholder or is there roll-over relief?

*EVL § 52b does not require that the shareholders be Finnish residents, but the provision applies the same way to Finnish and non-resident shareholders. The exchange of the shares in the transferring company for shares in the recipient company is not treated as a taxable event for the non-resident shareholders. The deductible acquisition cost of the shares, which were received as a consideration, is equal to the acquisition cost of the shares in the transferring company. The possible cash payment used for consideration instead is subject to the capital gains treatment. Non-residents, however, are not liable to pay any taxes for capital gains on movable property in Finland unless the gain is connected with a permanent establishment in Finland.*

- i) Will the answers to the questions 1g) and 1h) differ if SH A is:
- i) A corporate shareholder?  
*No difference.*
- ii) An individual shareholder not owning a substantial interest?

*No difference.*

- iii) An individual shareholder owning a substantial interest?

*No difference.*

- iv) An individual entrepreneur?

*No difference.*

- 2) Assume Member State S is Finland

Tax effects for SE in Member State S

- a) What is the value for tax purposes that SE has to attribute to the assets and liabilities, which are transferred to SE as part of the merger and that form a permanent establishment in Member States A, B and C?

*All assets and liabilities get the same value as they had in the books of the distributing company (A) at the moment of the merger (EVL 52b§).*

Tax effects for shareholder(s) of SE in Member State S

- b) Is there any provision in the legislation of Member State S that affects the shareholder of SE whether resident in Member State S or not? For example, are there provisions with regard to the valuation of the shares received in SE?

*According to EVL § 52b the exchange of the shares in the transferring company for shares in the recipient company is not treated as a taxable event for the shareholders. The deductible acquisition cost of the shares, which were received as a consideration, is equal to the acquisition cost of the shares in the transferring company. EVL § 52b does not require that the shareholders be Finnish residents, but the provision applies the same way to Finnish and non-resident shareholders. The possible cash payment used for consideration instead is subject to the capital gains treatment. Only residents, however, are liable for taxes for capital gains on movable property.*

- 3) Assume Member State C is Finland

Tax effects for A and SE in Member State C in respect of its permanent establishment in Member State C

- a) Will the merger give rise to any taxation of capital gains (= real value of assets & liabilities transferred minus their value for tax purposes) or is there roll-over relief?

*The merger gives rise to taxation in Finland only if the property connected with the permanent establishment in Finland is transfer to abroad. Such transfer is treated as an alienation for Finnish tax purpose. The current value of the transferred property is included in the taxable profits of the permanent establishment.<sup>33</sup>*

---

<sup>33</sup> EVL § 51e.

- b) May provisions and reserves, which are partly or wholly exempt from tax and which are not derived from permanent establishments outside Member State C, be taken over with the same roll-over relief by the permanent establishment of SE in Member State C?

*Yes. According to EVL § 52b(2) provisions and reserves may be used in the receiving company the same way as they would have been used in the distributing company.*

- c) Will SE's permanent establishment in Member State C be allowed to take over the losses of A's permanent establishment that have not been exhausted for tax purposes? If SE would be a company resident in Member State C, would it then be allowed to take over these losses?

*Possible not yet exhausted losses of the transferring company (A) may be used in the receiving company (SE) the same way as they could have been used in the transferring company (A), provided that the company (SE) or its shareholders held over 50 % of the shares of the transferring company from the moment from which the items originate.<sup>34</sup>*

#### *CASES 3-6 Exchange of Shares*

*The Finnish special domestic law provisions on an exchange of shares are included in EVL § 52f and TVL § 45(2).<sup>35</sup> The same provisions apply to domestic arrangements and arrangements involving a company from another EU Member State.<sup>36</sup>*

*In an exchange of shares a company limited by shares acquires a sufficient number of shares in another company limited by shares to give it the majority of the voting rights. The parties may be also such companies from other EU Member States, which are covered by the Merger Directive and are liable to pay corporate taxes mentioned in the Directive.<sup>37</sup> The companies should not need to conduct business.<sup>38</sup>*

*The acquiring company issues new shares to the shareholders of the other company as a consideration.<sup>39</sup> The Merger Directive, however, does not require that the shares should be new, for which the requirement should not apply to arrangements involving a company from another EU Member State.<sup>40</sup> A part of the compensation, corresponding to 10 per cent of the nominal value of the shares received as compensation at the most, may consist of a cash payment.<sup>41</sup> The special provisions do not include any special*

---

<sup>34</sup> TVL §§ 122 and 123.

<sup>35</sup> The section applies to arrangements falling under the Business Income Tax Act. There is no special provision applying to arrangements falling under the Income Tax Act.

<sup>36</sup> EVL §§ 52(2) and 52e.

<sup>37</sup> EVL § 52(2).

<sup>38</sup> See the so-called Leur-Bloem case (C-28/95) of the EC Court.

<sup>39</sup> EVL § 52f.

<sup>40</sup> Article 2 of the Merger Directive.

<sup>41</sup> EVL § 52f.

*requirements with respect to the shareholder. A resident of any state thus should qualify. The tax benefits however seem to be available only for a resident of a EU Member State.*

*An exchange of shares is not treated as a taxable transfer except with respect to the possible cash payment. Because of the factual change in the ownership, the possible unused losses and unused imputation credits, tax excesses or dividend excesses may be lost.<sup>42</sup>*

*The special provisions include an exit tax type provision. The tax benefit is lost if the taxpayer becomes a non-resident for Finnish domestic law or tax treaty purposes within three years of the end of the tax year in which the exchange took place. The exempted amount is then taxable income for the year, in which the taxpayer became a non-resident.<sup>43</sup>*

---

<sup>42</sup> TVL § 122 § and YHL § 5a(1), 6d and 8(3).

<sup>43</sup> EVL § 52f(3) and TVL § 45(2).

### CASE 3

#### *Formation of a Holding – SE – 1*

(Art. 2 par. 2(a) jo. Art. 32, Art. 33 and Art. 34 Reg. 2157/2001)

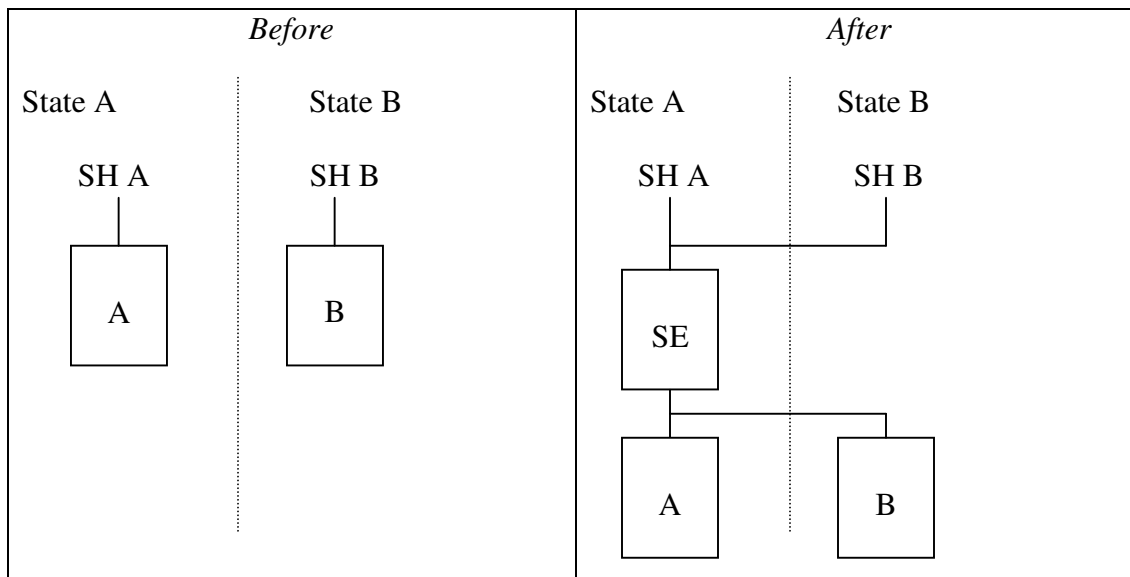

#### Facts and assumptions

- SH = shareholder(s), resident in the respective country in which SH is situated
- A and B are existing companies
- SE is a new company
- A and B are public or private limited-liability companies (see Annex II Reg. 2157/2001)
- State A and State B are EU Member States
- A:
  - formed under law of Member State A
  - registered office in Member State A
  - head office in Member State A
- B:
  - formed under law of Member State B
  - registered office in Member State B
  - head office in Member State B
- SE:
  - formed under law of Member State A
  - registered office in Member State A
  - head office in Member State A
  - will be covered by the EC Merger Directive

### ***Transactions***

- SE:
  - will be regarded as public limited-liability company governed by the law of Member State A
  - acquires holding in A and B
  - such that it obtains more than 50% of the permanent voting rights in A and B
  - in exchange for shares in SE
  - issued to the shareholders of A and B

### **Questions**

- 1) Assume Member State A is Finland

#### Tax effects for SE in Member State A (Finland)

- a) Are there any provisions for the valuation for tax purposes of the shares in A and B acquired by SE? Do the shares have to be valued at the book value of the exchanging shareholder or at a higher value?

*An exchange of shares is not treated as a taxable transfer except with respect to the possible cash payment. There are, however, no express provisions for the valuation of the shares acquired by SE. It is not totally clear whether the book value or the current value should be used. There is, however, a decision of the Central Tax Board of Finland (KVL 1997/131), where the current value was used.*

- b) Are there any provisions for the valuation for tax purposes of the shares issued to SH A and SH B? Do the shares have to be valued at the book value of the shares exchanged by the shareholder or at a higher value?

*An exchange of shares is not treated as a taxable transfer except with respect to the possible cash payment. The tax value of the received shares (SE shares) is the book value of the alienated shares (A shares for SH A and B shares for SH B).<sup>44</sup>*

#### Tax effects for SH A in Member State A (Finland)

- c) Will the issue of shares by SE to SH A in exchange for shares in A give rise to any taxation of the income, profits or capital gains of SH A or is there roll-over relief?

*An exchange of shares is not treated as a taxable transfer except with respect to the possible cash payment, which is subject to capital gains treatment. The tax value of the*

---

<sup>44</sup> EVL § 52f(2).

*received shares (SE shares) is the book value of the alienated shares (A shares for SH A).*<sup>45</sup>

*There is, however, an exit tax type provision. The tax benefit is lost if the taxpayer becomes a non-resident for Finnish domestic law or tax treaty purposes within three years of the end of the tax year in which the exchange took place. The exempted amount is then taxable income for the year, in which the taxpayer became a non-resident.*<sup>46</sup>

- d) Will the answers to the question 1c) differ if SH A is:
- i) A corporate shareholder?  
*No difference.*
  - ii) An individual shareholder not owning a substantial interest?  
*No difference.*
  - iii) An individual shareholder owning a substantial interest?  
*No difference.*
  - iv) An individual entrepreneur?  
*No difference.*

2) Assume Member State B is Finland

Tax effects for SH B in Member State B

- a) Will the issue of shares by SE to SH B in exchange for shares in B give rise to any taxation of the income, profits or capital gains of SH B or is there roll-over relief?

*An exchange of shares is not treated as a taxable transfer except with respect to the possible cash payment, which is subject to capital gains treatment. The tax value of the received shares (SE shares) is the book value of the alienated shares (B shares for SH B).*<sup>47</sup>

*There is however, an exit tax type provision. The tax benefit is lost if the taxpayer becomes a non-resident for Finnish domestic law or tax treaty purposes within three years of the end of the tax year in which the exchange took place. The exempted amount is then taxable income for the year, in which the taxpayer became a non-resident.*<sup>48</sup>

- b) Will the answers to the question 1a) differ if SH B is:
- i) A corporate shareholder?  
*No difference.*
  - ii) An individual shareholder not owning a substantial interest?  
*No difference.*
  - iii) An individual shareholder owning a substantial interest?

---

<sup>45</sup> EVL § 52f(2).

<sup>46</sup> EVL § 52f(3) and TVL § 45(2).

<sup>47</sup> EVL § 52f(2).

<sup>48</sup> EVL § 52f(3) and TVL § 45(2).

*No difference.*

iv) An individual entrepreneur?

*No difference.*

## CASE 4

### *Formation of a Holding – SE*

(Art. 2 par. 2(a) and (b) jo. Art. 32, Art. 33, and Art. 34 Reg. 2157/2001)

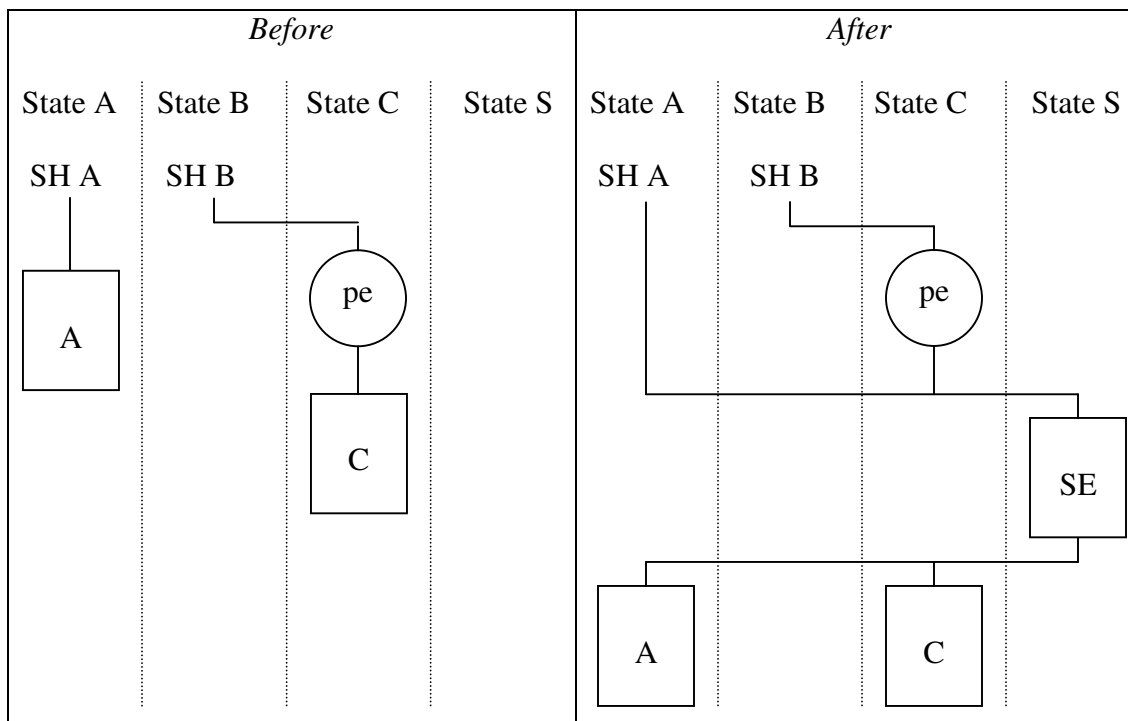

### Facts and assumptions

- SH = shareholder(s), resident in the respective country in which SH is situated
- A and C are existing companies
- The shares in C are attributable to pe in State C
- SE is a new company
- A and C are public or private limited-liability companies (see Annex II)
- State A, State B, State C and State S are EU Member States
- A:
  - formed under law of Member State A
  - registered office in Member State A
  - head office in Member State A
- C:
  - formed under law of Member State C



- registered office in Member State C
- head office in Member State C
- SE:
  - formed under law of Member State S
  - registered office in Member State S
  - head office in Member State S
  - will be covered by the EC Merger Directive

### Transactions

- SE:
  - will be regarded as public limited-liability company governed by the law of Member State S
  - acquires holding in A and C
  - such that it obtains more than 50% of the permanent voting rights in A and C
  - in exchange for shares in SE
  - issued to the shareholders of A and C

### Questions

1) Assume Member State A is Finland

#### Tax effects for SH A in Member State A

- a) Will the issue of shares by SE to SH A in exchange for shares in A give rise to any taxation of the income, profits or capital gains of SH A or is there roll-over relief?

*An exchange of shares is not treated as a taxable transfer except with respect to the possible cash payment, which is subject to capital gains treatment. The tax value of the received shares (SE shares) is the book value of the alienated shares (A shares for SH A).<sup>49</sup>*

*There is however, an exit tax type provision. The tax benefit is lost if the taxpayer becomes a non-resident for Finnish domestic law or tax treaty purposes within three years of the end of the tax year in which the exchange took place. The exempted amount is then taxable income for the year, in which the taxpayer became a non-resident.<sup>50</sup>*

- b) Will the answer to the above question be different in the case of:
- i) SH A being an individual shareholder not owning a substantial interest?  
*No difference.*
  - ii) SH A being an individual shareholder owning a substantial interest?  
*No difference.*

---

<sup>49</sup> EVL § 52f(2).

<sup>50</sup> EVL § 52f(3) and TVL § 45(2).

- iii) SH A being an individual entrepreneur?  
*No difference.*
- iv) SH A being a corporate shareholder?  
*No difference.*

2) Assume Member State B is Finland

Tax effects for SH B in Member State B

- a) Will the issue of shares by SE to SH B in exchange for shares in C give rise to any taxation of the income, profits or capital gains of SH B or is there roll-over relief?

*An exchange of shares is not treated as a taxable transfer except with respect to the possible cash payment, which is subject to capital gains treatment. The tax value of the received shares (SE shares) is the book value of the alienated shares (C shares for SH B).<sup>51</sup>*

*There is however, an exit tax type provision. The tax benefit is lost if the taxpayer becomes a non-resident for Finnish domestic law or tax treaty purposes within three years of the end of the tax year in which the exchange took place. The exempted amount is then taxable income for the year, in which the taxpayer became a non-resident.<sup>52</sup>*

- b) Will the answer to the above question be different in the case of:
  - i) SH B being an individual entrepreneur?  
*No difference.*
  - ii) SH B being a corporate shareholder?  
*No difference.*

3) Assume Member State C is Finland

Tax effects for SH B in Member State C

- a) Will the issue of shares by SE to SH B in exchange for shares in C give rise to any taxation of the income, profits or capital gains of SH B or is there roll-over relief?

*An exchange of shares is not treated as a taxable transfer except with respect to the possible cash payment, which is subject to capital gains treatment. The tax value of the received shares (SE shares) is the book value of the alienated shares (C shares for SH B).<sup>53</sup>*

---

<sup>51</sup> EVL § 52f(2).

<sup>52</sup> EVL § 52f(3) and TVL § 45(2).

<sup>53</sup> EVL § 52f(2).

*The special exit tax type provision of EVL § 52f (3) should not apply in this situation, because the shareholder was already a non-resident. However, the re-organization gives rise to taxation in Finland for a corporate shareholder, if the property connected with the permanent establishment in Finland is transferred abroad. Such transfer is treated as an alienation for Finnish tax purpose under EVL § 51e. The current value of the transferred property is then included in the taxable profits of the permanent establishment.<sup>54</sup>*

- b) Will the answer to the above question be different in the case of:
  - i) SH B being an individual entrepreneur?  
*EVL § 51e does not apply.*
  - ii) SH B being a corporate shareholder?  
*EVL § 51e may apply.*

4) Assume Member State S is Finland

Tax effects for SE in Member State S

- a) Are there any provisions for the valuation for tax purposes in Member State S of the shares of A and C acquired by SE? Do the shares have to be valued at the book value of the exchanging shareholder or at a higher value?

*An exchange of shares is not treated as a taxable transfer except with respect to the possible cash payment. There are, however, no express provisions for the valuation of the shares acquired by SE. It is, therefore, not totally clear whether the book value or the current value should be used. There is a decision of the Central Tax Board of Finland (KVL 1997/131), where the current value was used.*

- b) Are there any provisions for the valuation for tax purposes in Member State S of the shares issued to SH A and SH B? Do the shares have to be valued at the book value of the shares exchanged by the shareholder or at a higher value?

*An exchange of shares is not treated as a taxable transfer except with respect to the possible cash payment. The tax value of the received shares (SE shares) is the book value of the alienated shares (A shares for SH A and C shares for SH B).<sup>55</sup>*

---

<sup>54</sup> EVL § 51e.

<sup>55</sup> EVL § 52f(2).

## CASE 5

### *Formation of a Holding – SE*

(Art. 2 par. 2(b) jo. Art. 32, Art. 33, and Art. 34 Reg. 2157/2001)

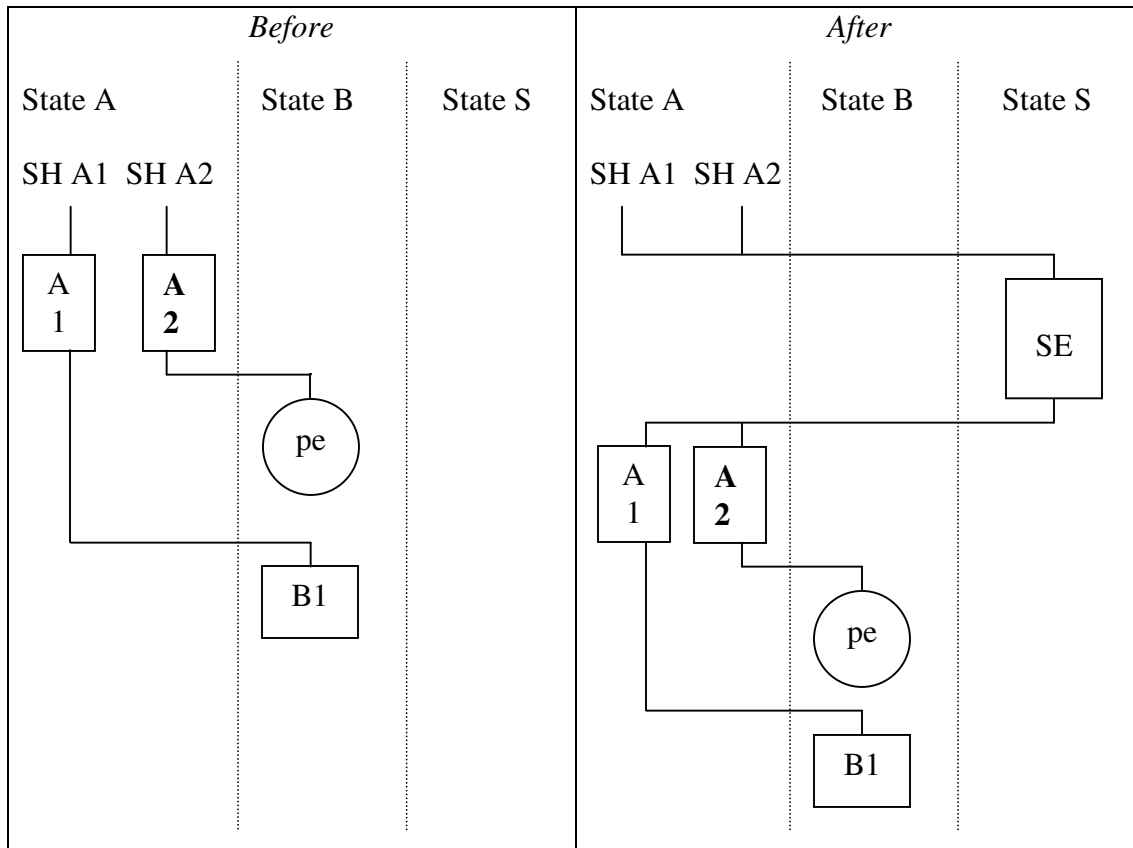

#### Facts and assumptions

- SH = shareholder(s), resident in the respective country in which SH is situated
- A1, A2, and B1 are existing companies
- pe is an existing permanent establishment of A2 in Member State B
- SE is a new company
- A1, A2, and B1 are public or private limited-liability companies (see Annex II to Reg. 2157/2001)
- State A, State B, and State S are EU Member States
- A1 and A2:
  - formed under law of Member State A
  - registered office in Member State A
  - head office in Member State A
- B1:
  - formed under law of Member State B

- registered office in Member State B
- head office in Member State B
- SE:
  - formed under law of Member State S
  - registered office in Member State S
  - head office in Member State S
  - will be covered by the EC Merger Directive

### Transactions

- SE:
  - will be regarded as public limited-liability company governed by the law of Member State S
  - acquires holding in A1 and A2
  - such that it obtains more than 50% of the permanent voting rights in A1 and A2
  - in exchange for shares in SE
  - issued to the shareholders of A1 and A2

### Questions

1) Assume Member State A is Finland

#### Tax effects for SH A2 in Member State A

- a) Will the issue of shares by SE to SH A2 in exchange for shares in A2 give rise to any taxation of the income, profits or capital gains of SH A2 or is there roll-over relief?

*An exchange of shares is not treated as a taxable transfer except with respect to the possible cash payment, which is subject to capital gains treatment. The tax value of the received shares (SE shares) is the book value of the alienated shares (A2 shares for SH A2).<sup>56</sup>*

*There is however, an exit tax type provision. The tax benefit is lost if the taxpayer becomes a non-resident for Finnish domestic law or tax treaty purposes within three years of the end of the tax year in which the exchange took place. The exempted amount is then taxable income for the year, in which the taxpayer became a non-resident.<sup>57</sup>*

- b) Will the answer to the above question be different in the case of:
- i) SH A2 being an individual shareholder not owning a substantial interest?  
*No difference.*
  - ii) SH A2 being an individual shareholder owning a substantial interest?  
*No difference.*

---

<sup>56</sup> EVL § 52f(2).

<sup>57</sup> EVL § 52f(3) and TVL § 45(2).

- iii) SH A2 being an individual entrepreneur?  
*No difference.*
- iv) SH A2 being a corporate shareholder?  
*No difference.*

2) Assume Member State S is Finland

Tax effects for SE in Member State S

- a) Are there any provisions for the valuation for tax purposes in Member State S of the shares of A1 and A2 acquired by SE? Do the shares have to be valued at the book value of the exchanging shareholder or at a higher value?

*An exchange of shares is not treated as a taxable transfer except with respect to the possible cash payment. There are, however, no express provisions for the valuation of the shares acquired by SE. It is, therefore, not totally clear whether the book value or the current value should be used. There is a decision of the Central Tax Board of Finland (KVL 1997/131), where the current value was used.*

- b) Are there any provisions for the valuation for tax purposes in Member State S of the shares issued to SH A1 and SH A2? Do the shares have to be valued at the book value of the shares exchanged by the shareholder or at a higher value?

*An exchange of shares is not treated as a taxable transfer except with respect to the possible cash payment. The tax value of the received shares (SE shares) is the book value of the alienated shares (A1 shares for SH A1 and A2 shares for SH A2).<sup>58</sup>*

---

<sup>58</sup> EVL § 52f(2).

## CASE 6

### *Formation of a Subsidiary–SE by exchange of shares* (Art. 2 par. 3(a) jo. Arts. 35 and 36 Reg. 2157/2001)

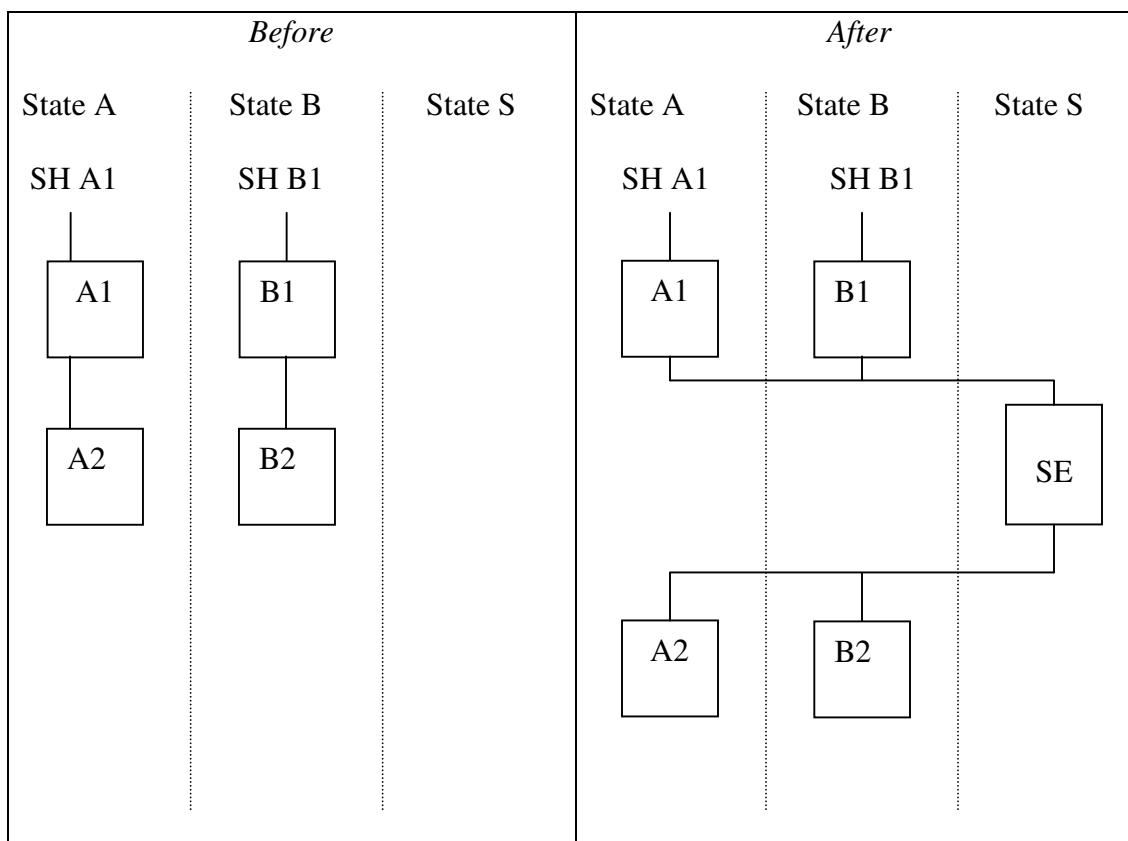

#### Facts and assumptions

- SH = shareholder(s), resident in the respective country in which SH is situated
- A1, A2, B1, and B2 are existing companies
- SE is a new company
- A1 and B1 are companies or firms within the meaning of Art. 48 par. 2 of the Treaty establishing the European Community or other legal bodies governed by public or private law (Art. 2 par. 3 Reg. 2157/2001)
- State A, State B, and State S are EU Member States
- A1 and A2:
  - formed under law of Member State A
  - registered office in Member State A
  - head office in Member State A
- B1 and B2:
  - formed under law of Member State B

- registered office in Member State B
- head office in Member State B
  
- SE:
  - formed under law of Member State S
  - registered office in Member State S
  - head office in Member State S
  - will be covered by the EC Merger Directive

### Transactions

- A1 and B1:
  - *form a subsidiary SE by way of contributing their subsidiaries A2 and B2 respectively to SE*
- SE:
  - will be regarded a public limited-liability company governed by the law of Member State S
  - will acquire the shares in A2 and B2 in exchange for shares issued to A1 and B1

### Questions

1) Assume Member State A is Finland

#### Tax effects for A1 in Member State A

- a) Will the issue of shares by SE to A1 in exchange for shares in A2 give rise to any taxation of the income, profits or capital gains of A1 or is there roll-over relief?

*An exchange of shares is not treated as a taxable transfer except with respect to the possible cash payment, which is subject to capital gains treatment. The tax value of the received shares (SE shares) is the book value of the alienated shares (A2 shares for A1).<sup>59</sup>*

*There is however, an exit tax type provision. The tax benefit is lost if the taxpayer becomes a non-resident for Finnish domestic law or tax treaty purposes within three years of the end of the tax year in which the exchange took place. The exempted amount is then taxable income for the year, in which the taxpayer became a non-resident.<sup>60</sup>*

2) Assume Member State S is Finland

#### Tax effects for SE in Member State S

---

<sup>59</sup> EVL § 52f(2).

<sup>60</sup> EVL § 52f(3) and TVL § 45(2).



- a) Are there any provisions for the valuation for tax purposes in Member State S of the shares of A2 and B2 acquired by SE? Do the shares have to be valued at the book value of the exchanging shareholder or at a higher value?

*An exchange of shares is not treated as a taxable transfer except with respect to the possible cash payment. There are, however, no express provisions for the valuation of the shares acquired by SE. It is, therefore, not totally clear whether the book value or the current value should be used. There is a decision of the Central Tax Board of Finland (KVL 1997/131), where the current value was used.*

- b) Are there any provisions for the valuation for tax purposes in Member State S of the shares issued to A1 and B1? Do the shares have to be valued at the book value of the shares exchanged by the shareholder or at a higher value?

*An exchange of shares is not treated as a taxable transfer except with respect to the possible cash payment. The tax value of the received shares (SE shares) is the book value of the alienated shares (A2 shares for A1 and B2 shares for B1).<sup>61</sup>*

---

<sup>61</sup> EVL § 52f(2).

## CASE 7

### *Formation of a Subsidiary–SE by contribution of cash* (Art. 2 par. 3(a) jo. Arts. 35 and 36 Reg. 2157/2001)

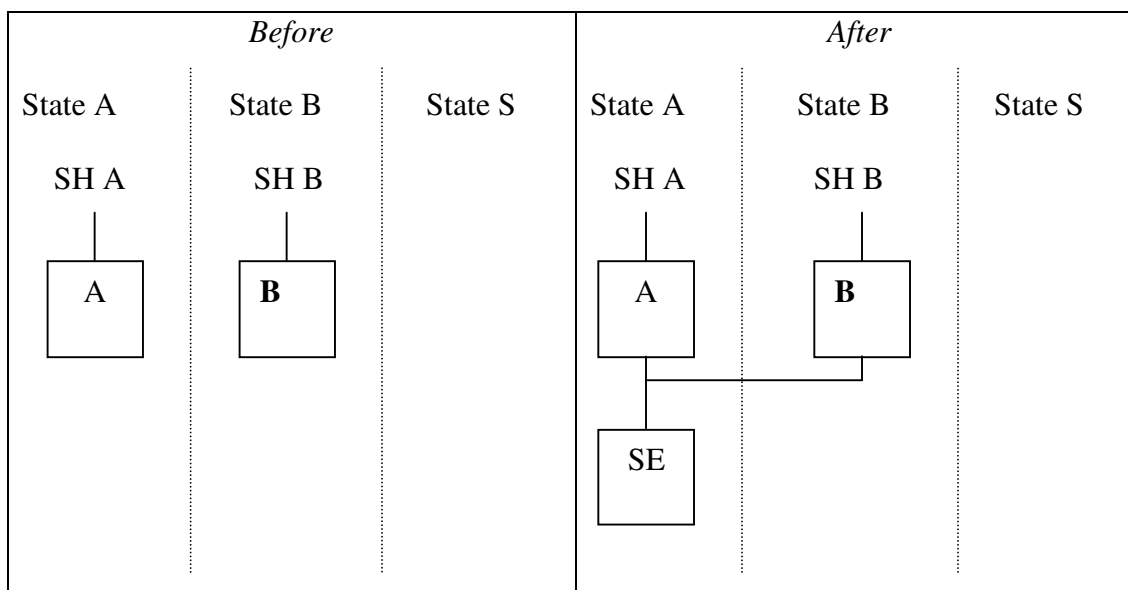

#### Facts and assumptions

- SH = shareholder(s), resident in the respective country in which SH is situated
- A, and B are existing companies
- SE is a new company
- A and B are companies or firms within the meaning of Art. 48 par. 2 of the Treaty establishing the European Community or other legal bodies governed by public or private law (Art. 2 par. 3 Reg. 2157/2001)
- State A, State B, and State S are EU Member States
- A:
  - formed under law of Member State A
  - registered office in Member State A
  - head office in Member State A
- B:
  - formed under law of Member State B
  - registered office in Member State B
  - head office in Member State B
- SE:
  - formed under law of Member State A
  - registered office in Member State A
  - head office in Member State A
  - will be covered by the EC Merger Directive

### **Transactions**

- SE:
  - will take the form of an SE
  - will be regarded a public limited-liability company governed by the law of Member State A
- A and B:
  - *form a subsidiary SE*

### *Overview of the Finnish Rules*

*Most Finnish tax law rules refer to corporate bodies, without specifying, which corporate bodies are covered. These rules will automatically apply to SEs. It is also likely that the rules that refer to a Finnish corporate body will be applied to an SE with its registered office in Finland, even though SEs would not expressly be added to the provisions. Some rules, however, refer expressly only to the Finnish osakeyhtiö (Finnish limited companies). It is unclear whether also these rules will be applied to an SE with its registered office in Finland unless SEs will be expressly added to the provisions. If the rules are applied strictly by their wording, they do not apply to SEs. In some cases, however, it may be possible that the rules will be applied by analogy also to SEs. It may also be imagined, that in some cases for example the non-discrimination article or for example the four basic freedoms of the EC Treaty may be said to require that the domestic law rules be applied to SEs.*

*For example the Finnish dividend imputation credit system applies expressly only to profit distributions from a domestic osakeyhtiö and from some other domestic expressly mentioned entity forms.<sup>62</sup> An imputation credit would thus not be attached with dividends distributed by an SE with its registered office in Finland, unless the Imputation Credit Act would be amended to cover expressly also SEs. It is, however, very likely that the EC Treaty (e.g. the principle of non-discrimination or the freedom of establishment) should be interpreted requiring that imputation credit be attached the same way to dividends from an SE with a registered office in Finland as to dividends from Finnish osakeyhtiös. The credit should thus be attached to the profit distributions even though the Act on Imputation Credit would not be expressly amended.*

*The same way the Finnish regime allowing the balancing of profits and losses among companies in a group of companies by means of a tax deductible and taxable group contribution applies only to Finnish osakeyhtiös and some other expressly mentioned Finnish entity forms.<sup>63</sup> Therefore, an SE cannot be a giver or recipient of a tax-deductible group contribution, unless SEs will be expressly included in the Act on Group Contribution. The same way as with respect to the dividend imputation system, it is, however, very likely that the EC Treaty (e.g. the principle of non-discrimination or the*

---

<sup>62</sup> YHL § 1 (Act on Imputation Credit).

<sup>63</sup> *KonserniavustusL* § 1 (Act on Group Contribution).

*freedom of establishment) should be interpreted requiring that group contribution is possible also for SEs with a registered office in Finland. SEs should thus be entitled to give or receive a group contribution even though the Act on Group Contribution would not be expressly amended. For the sake of clarity, it is however recommended that both the Act on Imputation Credit and the Act on Group Contribution will be expressly amended to cover SEs.*

## **Questions**

- 1) Assume Member State A is Finland

### Tax effects for A in Member State A

Will there be any tax effect for A in Member State A as a consequence of the formation of the subsidiary SE in Member State A?

*There are no tax effects.*

- 2) Assume Member State B is Finland

### Tax effects for B in Member State B

Will there be any tax effect for B in Member State B as a consequence of the formation of the subsidiary SE in Member State A?

*There are no tax effects.*

## CASE 8

### *Formation of a Subsidiary–SE by transfer of assets*

(Art. 2 par. 3(a) jo. Arts. 35 and 36 Reg. 2157/2001)

*The Finnish special domestic law provisions on a transfer of assets are included in EVL § 52d.<sup>64</sup> The same provision applies to domestic arrangements and arrangements involving a company from another EU Member State.<sup>65</sup>*

*In a transfer of assets a corporate body transfers all its assets or the assets of one or more branches of its business activity and the corresponding liabilities to a corporate body, which continues the activity.<sup>66</sup> The parties may be also such companies from other EU Member States, which are covered by the Merger Directive and are liable to pay corporate taxes mentioned in the Directive.<sup>67</sup> The transferring company receives as a consideration new shares issued by the recipient company.<sup>68</sup> The Merger Directive, however, does not require that the shares should be new, for which the requirement should not apply to arrangements involving a company from another EU Member State.<sup>69</sup>*

*A transfer of assets does not realize any taxable income, provided that the book values are used as the transfer price. In the taxation of the transferring company the book value of the acquisition costs of the transferred assets is the taxable alienation price.<sup>70</sup> The corresponding value is the deductible acquisition cost for the recipient company. Other costs are deductible the same way as they would have been deductible by the transferring company.<sup>71</sup> Reserves are deemed to be taxable income in the same way as they were taxable income for the transferring company. The deductible acquisition cost of the new shares received by the transferring company is the book value of the transferred assets minus the transferred debts and reserves.<sup>72</sup> Possible non-deducted losses and unused imputation credits, tax excesses or dividend excesses<sup>73</sup> of the transferring company are not transferred to the recipient company. A company, which was established to continue the business of a company of another EU Member State carried out through a permanent establishment in Finland, however is entitled to deduct the unused losses of the permanent establishment.<sup>74</sup>*

---

<sup>64</sup> The section applies to arrangements falling under the Business Income Tax Act. There is no special provision applying to arrangements falling under the Income Tax Act.

<sup>65</sup> EVL §§ 52(2) and 52e.

<sup>66</sup> EVL §52d(1).

<sup>67</sup> EVL § 52(2).

<sup>68</sup> EVL § 52d(1).

<sup>69</sup> Article 2 of the Merger Directive.

<sup>70</sup> EVL § 52d(2).

<sup>71</sup> EVL § 52d(3).

<sup>72</sup> EVL § 52d(4).

<sup>73</sup> These are items relating to the Finnish dividend imputation system that decrease the tax liability of a company.

<sup>74</sup> TVL § 123a.

*If the receiving company is from another EU Member State, the special treatment in Finland is applicable only if the transferred assets remain connected with a permanent establishment in Finland.<sup>75</sup> If the assets do not remain in a permanent establishment in Finland, the current value of the assets is taxable income in Finland.<sup>76</sup>*

*A special provision applies to situations in which the assets, transferred from a Finnish company to a company of another EU Member State, were connected with a permanent establishment of the Finnish company in another EU Member State.<sup>77</sup> The current value of the transferred assets is included in the taxable income of the Finnish transferring company in such a situation. The tax, which the company would have paid in the permanent establishment state for the same income, if the Merger Directive had not applied, however is deducted from the tax in Finland. The income may be totally tax-exempt if an applicable tax treaty requires Finland to apply the exemption method with respect to permanent establishments.*

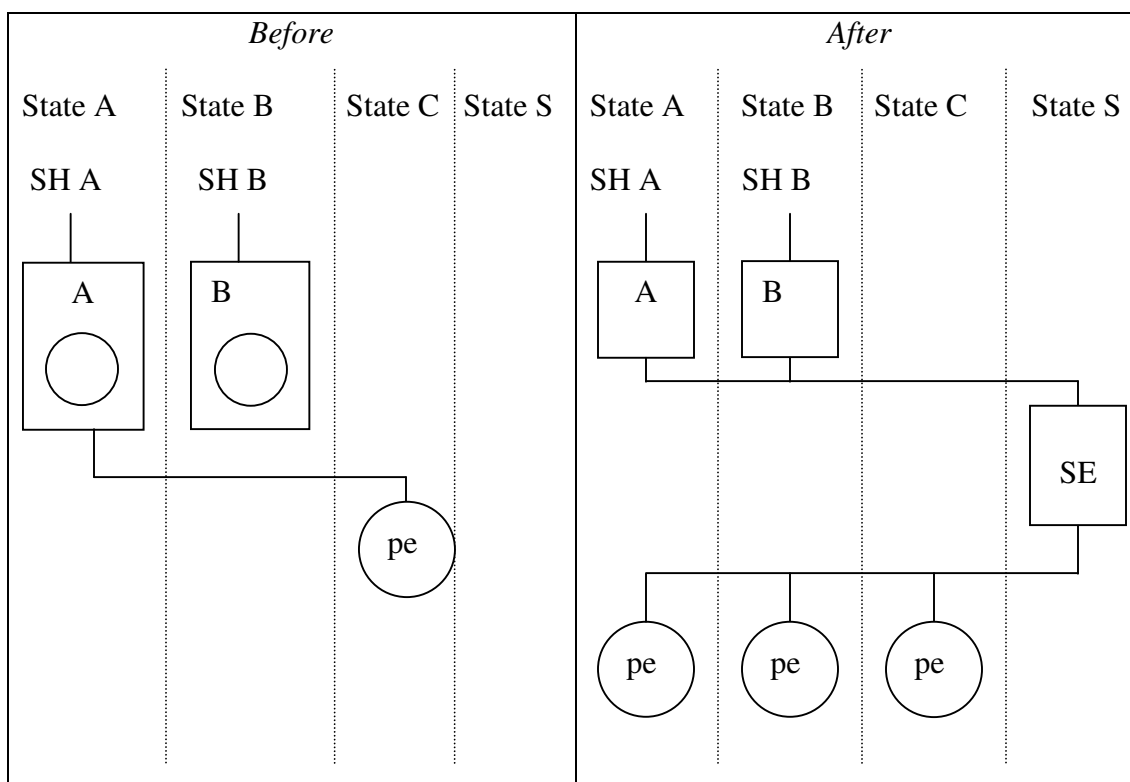

### Facts and assumptions

- SH = shareholder(s), resident in the respective country in which SH is situated

<sup>75</sup> EVL § 52e(1).

<sup>76</sup> EVL § 52e(2).

<sup>77</sup> EVL § 52e(3).

- A, and B are existing companies
- SE is a new company
- A and B are public or private limited-liability companies (see Annex II)
- A and B are companies or firms within the meaning of Art. 48 par. 2 of the Treaty establishing the European Community or other legal bodies governed by public or private law
- A has a permanent establishment in State C
- State A, State B, State C and State S are EU Member States
- A:
  - formed under law of Member State A
  - registered office in Member State A
  - head office in Member State A
- B:
  - formed under law of Member State B
  - registered office in Member State B
  - head office in Member State B
- SE:
  - formed under law of Member State S
  - registered office in Member State S
  - head office in Member State S
  - will be covered by the EC Merger Directive

### Transactions

- SE:
  - will take the form of an SE
  - will be regarded a public limited-liability company governed by the law of Member State S
- A (and B):
  - *form a subsidiary by way of contributing their branches in Member State A (and B respectively) to SE in exchange for the issue of shares by SE to A (and B respectively)*
- A:
  - will transfer its permanent establishment in Member State C to SE in exchange for the issue of shares by SE to A

### Questions

1) Assume Member State A is Finland

#### Tax effects for A and SE in Member State A

- a) Will the transfer of assets give rise to any taxation of capital gains (= real value of the assets and liabilities minus their value for tax purposes) or is there roll-over relief?

*A transfer of assets does not realize any taxable income, provided that the book values are used as the transfer price. In the taxation of the transferring company (A) the book value of the acquisition costs of the transferred assets is the taxable alienation price.<sup>78</sup> The corresponding value is the deductible acquisition cost for the recipient company (SE). Other costs are deductible the same way as they would have been deductible by the transferring company (A).<sup>79</sup> Reserves are deemed to be taxable income in the same way as they were taxable income for the transferring company (A). The deductible acquisition cost of the new shares received by the transferring company (A) is the book value of the transferred assets minus the transferred debts and reserves.<sup>80</sup> Possible non-deducted losses and unused imputation credits, tax excesses or dividend excesses<sup>81</sup> of the transferring (A) company are not transferred to the recipient company (SE).*

*Because the receiving company (SE) is from another EU Member State, the special treatment in Finland is applicable only if the transferred assets remain connected with a permanent establishment in Finland.<sup>82</sup> If the assets do not remain in a permanent establishment in Finland, the current value of the assets is taxable income in Finland.<sup>83</sup>*

*A special provision applies to the situations in which the assets, transferred from a Finnish company (A) to a company of another EU Member State (SE), were connected with a permanent establishment of the Finnish company in another EU Member State (State C).<sup>84</sup> The current value of the transferred assets is included in the taxable income of the Finnish transferring company (A) in such a situation. The tax, which the company would have paid in the permanent establishment state for the same income, if the Merger Directive had not applied, however, is deducted from the tax in Finland. The income may be totally tax-exempt if an applicable tax treaty requires Finland to apply the exemption method with respect to permanent establishments.*

- b) May provisions or reserves which are partly or wholly exempt from tax and which are not derived from permanent establishments outside Member State A be taken over with the same roll-over relief by the permanent establishment of SE in Member State A?

*Any costs connected with the transferred assets are deductible for the receiving company (SE) the same way as they would have been deductible by the transferring company.<sup>85</sup> Reserves are deemed to be taxable income in the same way as they were taxable income for the transferring company (A). The deductible acquisition cost of the new shares received by the transferring company (A) is the book value of the transferred assets*

---

<sup>78</sup> EVL § 52d(2).

<sup>79</sup> EVL § 52d(3).

<sup>80</sup> EVL § 52d(4).

<sup>81</sup> These are items relating to the Finnish dividend imputation system, which decrease the tax liability of a company.

<sup>82</sup> EVL § 52e(1).

<sup>83</sup> EVL § 52e(2).

<sup>84</sup> EVL § 52e(3).

<sup>85</sup> EVL § 52d(3).



*minus the transferred debts and reserves.<sup>86</sup> Possible not yet exhausted losses and unused imputation credits, tax excesses or dividend excesses of the transferring company (A) instead are not transferred to the recipient company (SE). The Finnish tax law rules do not expressly state whether the same treatment applies with respect to a receiving company with a permanent establishment in Finland. However, because based on the general rules permanent establishments of companies from other EU Member States should be subject to the same tax benefits as Finnish companies, the same treatment should be available for the permanent establishment in Finland.*

- c) Are there any provisions in the legislation of Member State A for the valuation for tax purposes of the shares in SE acquired by A?

*In the taxation of the transferring company (A) the book value of the acquisition costs of the transferred assets is the taxable alienation price.<sup>87</sup> The deductible acquisition cost of the new shares (SE shares) received by the transferring company (A) is the book value of the transferred assets minus the transferred debts and reserves.<sup>88</sup>*

- d) Will SE's permanent establishment in Member State A be allowed to take over the losses of A which have not been exhausted for tax purposes? (If SE would be a company resident in Member State A, would it then be allowed to take over these losses?)

*Possible losses not yet exhausted and unused imputation credits, tax excesses or dividend excesses of the transferring company (A) are not transferred to the recipient company (SE). They may be exhausted only in the transferring company (A) and not in the permanent establishment of the receiving company (SE). The fact that SE would be a resident in Finland would not change this treatment.*

- e) Will Member State A renounce any right to tax the permanent establishment in Member State C?

*A special provision applies to situations in which the assets, transferred from a Finnish company (A) to a company of another EU Member State (SE), were connected with a permanent establishment of the Finnish company (A) in another EU Member State (C).<sup>89</sup> The current value of the transferred assets is included in taxable income of the Finnish transferring company (A) in such a situation. The tax, which the company would have paid in the permanent establishment state for the same income, if the Merger Directive had not applied, however, is deducted from the tax in Finland. The income may be totally tax-exempt if an applicable tax treaty requires Finland to apply the exemption method with respect to permanent establishments.*

---

<sup>86</sup> EVL § 52d(4).

<sup>87</sup> EVL § 52d(2).

<sup>88</sup> EVL § 52d(4).

<sup>89</sup> EVL § 52e(3).

- f) Will Member State A reinstate in the taxable profits of A such losses of the permanent establishment in Member State C as have been set off against the taxable profits of A in Member State A and which have not been recovered (see art. 10 par. 2 of the EC Merger Directive)?

*There will be no reinstatement.*

- g) and h) Or will Member State A tax profits or capital gains of the permanent establishment in State C resulting from the transfer of assets? If the question is answered affirmatively, will Member State A give relief for the notional tax charged on these profits or capital gains by Member State C, assuming that Member State C would have levied tax (see art 10 par. 2 of the EC Merger Directive)?

*A special provision applies to situations in which the assets, transferred from a Finnish company to a company of another EU Member State, were connected with a permanent establishment of the Finnish company in another EU Member State.<sup>90</sup> The current value of the transferred assets is included in taxable income of the Finnish transferring company in such a situation. The tax, which the company would have paid in the permanent establishment state for the same income, if the Merger Directive had not applied, however, is deducted from the tax in Finland. The income may be totally tax-exempt if an applicable tax treaty requires Finland to apply the exemption method with respect to permanent establishments.*

- 2) Assume Member State S is Finland

#### Tax effects for SE in Member State S

- a) What is the value for tax purposes that SE has to attribute to the assets and liabilities of the permanent establishments in Member States A, B and C that is transferred to SE as part of the merger?

*A transfer of assets does not realize any taxable income, provided that the book values are used as the transfer price. In the taxation of the transferring company (A) the book value of the acquisition costs of the transferred assets is the taxable alienation price.<sup>91</sup> The corresponding value is the deductible acquisition cost for the recipient company (SE). Other costs are deductible the same way as they would have been deductible by the transferring company (A).<sup>92</sup> Reserves are deemed to be taxable income in the same way as they were taxable income for the transferring company (A).*

#### Tax effects for A as shareholder of SE in Member State S

---

<sup>90</sup> EVL § 52e(3).

<sup>91</sup> EVL § 52d(2).

<sup>92</sup> EVL § 52d(3).

- b) Is there any provision in the tax legislation of Member State S that affects A as shareholder of SE?

*There will be no tax effects to shareholder A in Finland until SE makes a dividend distribution to A. The dividends from the SE will be tax-exempt for the shareholders under the Finnish rule implementing the requirements of the Parent-subsidiary Directive provided that a 25 % holding exists.<sup>93</sup>*

- 3) Assume Member State C is Finland

Tax effects for A and SE in Member State C in respect of its permanent establishment in Member State C

- a) Will the transfer of assets give rise to any taxation of capital gains (= real value of assets & liabilities transferred minus their value for tax purposes) or is there roll-over relief?

*A transfer of assets does not realize any taxable income, provided that the book values are used as the transfer price. In the taxation of the transferring company the book value of the acquisition costs of the transferred assets is the taxable alienation price.<sup>94</sup> The corresponding value is the deductible acquisition cost for the recipient company (SE). Other costs are deductible the same way as they would have been deductible by the transferring company.<sup>95</sup> Reserves are deemed to be taxable income in the same way as they were taxable income for the transferring company. The deductible acquisition cost of the new shares received by the transferring company is the book value of the transferred assets minus the transferred debts and reserves.<sup>96</sup> Possible not yet exhausted losses and unused imputation credits, tax excesses or dividend excesses<sup>97</sup> of the transferring company are not transferred to the recipient company. A company (SE), which was established to continue the business of a company of another EU Member State (A) carried out through a permanent establishment in Finland (State C), however is entitled to deduct the unused losses of the permanent establishment.<sup>98</sup>*

*If the receiving company is from another EU Member State, the special treatment in Finland is applicable only if the transferred assets remain connected with a permanent establishment in Finland.<sup>99</sup> If the assets do not remain in a permanent establishment in Finland, the current value of the assets is taxable income in Finland.<sup>100</sup>*

---

<sup>93</sup> LähdeveroL § 3(5).

<sup>94</sup> EVL § 52d(2).

<sup>95</sup> EVL § 52d(3).

<sup>96</sup> EVL § 52d(4).

<sup>97</sup> These are items relating to the Finnish dividend imputation system, which decrease the tax liability of a company.

<sup>98</sup> TVL § 123a.

<sup>99</sup> EVL § 52e(1).

<sup>100</sup> EVL § 52e(2).

- b) May provisions and reserves, which are partly or wholly exempt from tax and which are not derived from permanent establishments outside Member State C, be taken over with the same roll-over relief by the permanent establishment of SE in Member State C?

*Any costs are deductible the same way as they would have been deductible by the transferring company A.<sup>101</sup> Reserves are deemed to be taxable income in the same way as they were taxable income for the transferring company A.<sup>102</sup>*

- c) Will SE's permanent establishment in Member State C be allowed to take over the losses of A's permanent establishment that have not been exhausted for tax purposes? If SE would be a company resident in Member State C, would it then be allowed to take over these losses?

*A company (SE), which was established to continue the business of a company of another EU Member State (A) carried out through a permanent establishment in Finland (State C) is entitled to deduct the not yet exhausted losses of the permanent establishment whether or not the company is a Finnish company.<sup>103</sup>*

---

<sup>101</sup> EVL § 52d(3).

<sup>102</sup> EVL § 52d(3).

<sup>103</sup> TVL § 123a.

## CASE 9

### *Transformation of public limited-liability company into an SE*

(Art. 2 par. 4 jo. Art. 37 Reg. 2157/2001)

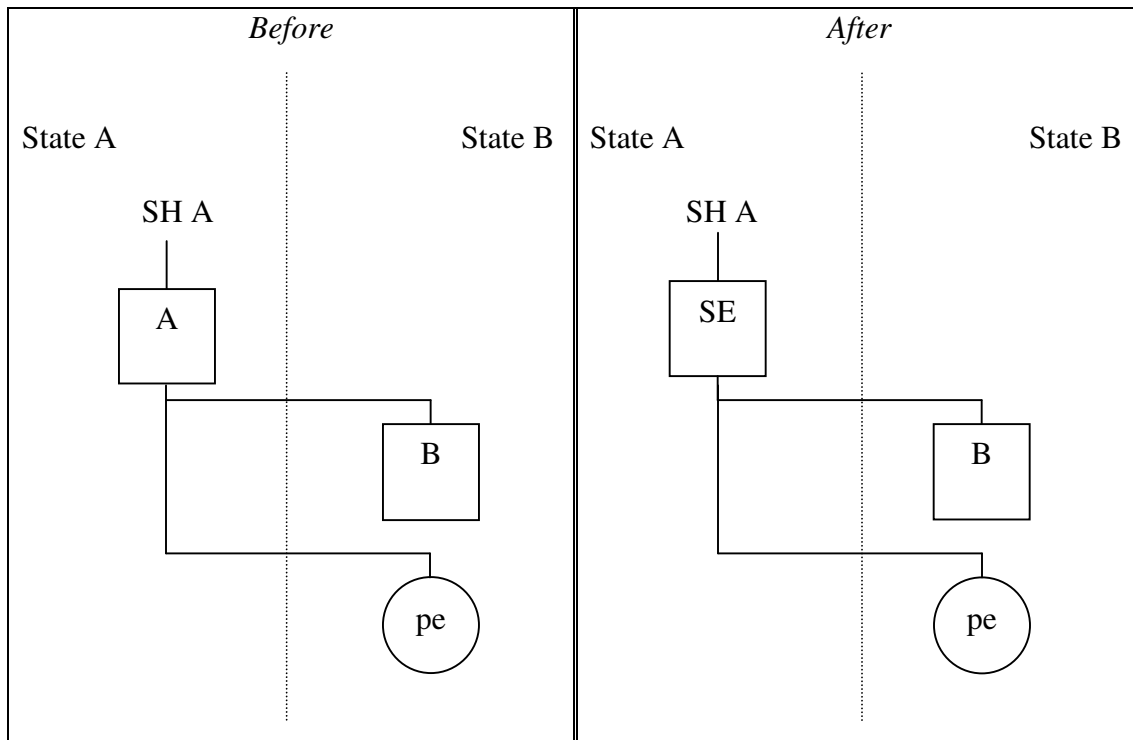

#### Facts and assumptions

- SH = shareholder(s), resident in the respective country in which SH is situated
- A and B are existing companies
- pe is an existing permanent establishment
- A and B public limited-liability companies (see Annex I of Reg. 2157/2001)
- State A and State B are EU Member States
- A:
  - formed under law of Member State A
  - registered office in Member State A
  - head office in Member State A
- B:
  - formed under law of Member State B
  - registered office in Member State B
  - head office in Member State B

#### Transactions

- A will be transformed into an SE, governed by the law of Member State A (Pursuant to Art. 37 par. 2 Reg., the transformation shall not result in the winding up of A or in the creation of a new legal person. However, the Regulation itself does not give guidance with regard to taxation.)

## Questions

- 1) Assume Member State A is Finland

### Tax effects for A in Member State A

- a) Will the transformation of A into an SE give rise to any taxation of capital gains (= real value of assets and liabilities transferred minus their value for tax purposes) or is there roll-over relief for the business carried on in Member State A, or in Member State B through a permanent establishment?

*Finnish tax law includes special rules (TVL § 24 § and EVL § 51c) allowing the transformation of different Finnish entity forms to another Finnish entity form. A transformation may be carried out without the transformed company to be dissolved for tax purposes and consequently without any direct tax consequences. According to TVL § 24(1)(6), the same tax treatment is applicable in any situation, that is comparable to the situations expressly covered by the special rules. Therefore, there seems to be no obstacle to apply the same treatment also, when a limited liability company is transformed to an SE. However, before some actual cases exist it is not totally certain whether this would be the interpretation of the Finnish tax authorities and the Finnish tax courts. Therefore, the best would be to include a transformation of a limited liability company expressly in TVL § 24. If the transformation does not qualify under the special rules, the company is regarded to dissolve for tax purposes, and the assets are regarded to be transferred for their current values, generally leading to capital gains tax treatment.<sup>104</sup>*

- b) May provisions and reserves, which are partly or wholly exempt from tax and which are not derived from permanent establishments outside Member State A, be carried over to SE in Member State A?

*If the special rules of TVL § 24 and EVL § 51c are regarded to apply to the transformation, provisions and reserves are carried over. If the special rules are interpreted not to apply to the transformation, there is no carry-over.*

- c) Will SE be allowed to take over the losses of A that have not been exhausted for tax purposes?

*If the special rules of TVL § 24 and EVL § 51c are regarded to apply to the transformation, SE will be allowed to take over the losses of A that have not yet been exhausted for tax purposes. If the special rules are interpreted not to apply to the transformation, there is no carry-over.*

---

<sup>104</sup> TVL § 27 and EVL § 51d.

Tax effects for SH A in Member State A

- d) Will there be any effect for SH A because of the transformation of its subsidiary company A into an SE?

*If the special rules of TVL § 24 and EVL § 51c are regarded to apply to the transformation, there will be no tax consequences for SH A. If SH A will later alienate the SE, the tax consequences will be determined as if the taxpayer had owned the SE since he owned company A and as if he had acquired the SE for the price he acquired A. If the special rules instead are not regarded to apply to the transformation, A is regarded to dissolve for tax purposes and the assets been transferred for current value leading to capital gain treatment.<sup>105</sup>*

- e) Will the answer to question d) be different in the following situations:
- i) SH is a corporate shareholder?  
*No difference.*
  - ii) SH is an individual shareholder not owning a substantial interest?  
*No difference.*
  - iii) SH is an individual shareholder owning a substantial interest?  
*No difference.*
  - iv) SH is an individual entrepreneur?  
*No difference.*

2) Assume Member State B is Finland

Tax effects for the shareholder of B in Member State B

- a) Will there be any effect for the shareholder of B because of the transformation of its parent company A into an SE?

*There will be no effect to the shareholders of B.*

Tax effects for A and SE in Member State B

- b) Will A be subject to any taxation of capital gains (=real value of assets and liabilities minus their value for tax purposes) or is there roll-over relief?

*If the special rules of TVL § 24 and EVL § 51c are regarded to apply to the transformation, there will be no taxation of capital gains in Finland. If the special rules instead are not regarded to apply to the transformation, the assets are regarded to have been transferred for current value, leading to capital gains treatment. Capital gains are taxable in Finland to the extent they are regarded to be connected with a permanent establishment in Finland.<sup>106</sup>*

---

<sup>105</sup> TVL § 27 and EVL § 51d.

<sup>106</sup> TVL §§ 9, 10 and 13a.

- c) If not, what is the value for tax purposes that SE has to attribute to the assets and liabilities of the permanent establishment in Member State B?

*If the special rules of TVL § 24 and EVL § 51c are regarded to apply, the assets are regarded to be transferred for their book-values. If the special rules are not regarded to apply the assets are regarded to be transferred for current values.<sup>107</sup>*

- d) May provisions and reserves, which are partly or wholly exempt from tax and which are not derived from permanent establishments outside Member State B, be taken over with the same roll-over relief by the permanent establishment of SE in Member State B?

*If the special rules of TVL § 24 and EVL § 51c are regarded to apply to the transformation, provisions and reserves are carried over. If the special rules are interpreted not to apply to the transformation, there is no carry-over.*

- e) Will SE's permanent establishment in Member State B be allowed to take over the losses of A's permanent establishment that have not been exhausted for tax purposes?

*If the special rules of TVL § 24 and EVL § 51c are regarded to apply to the transformation, SE will be allowed to take over the losses of A that have not yet been exhausted for tax purposes. If the special rules are interpreted not to apply to the transformation, there is no carry-over.*

---

<sup>107</sup> TVL § 27 and EVL § 51d.



## CASE 10

### *Transfer of registered office of an SE*

(Art. 8 par. 1 jo. Art. 37 Reg. 2157/2001)

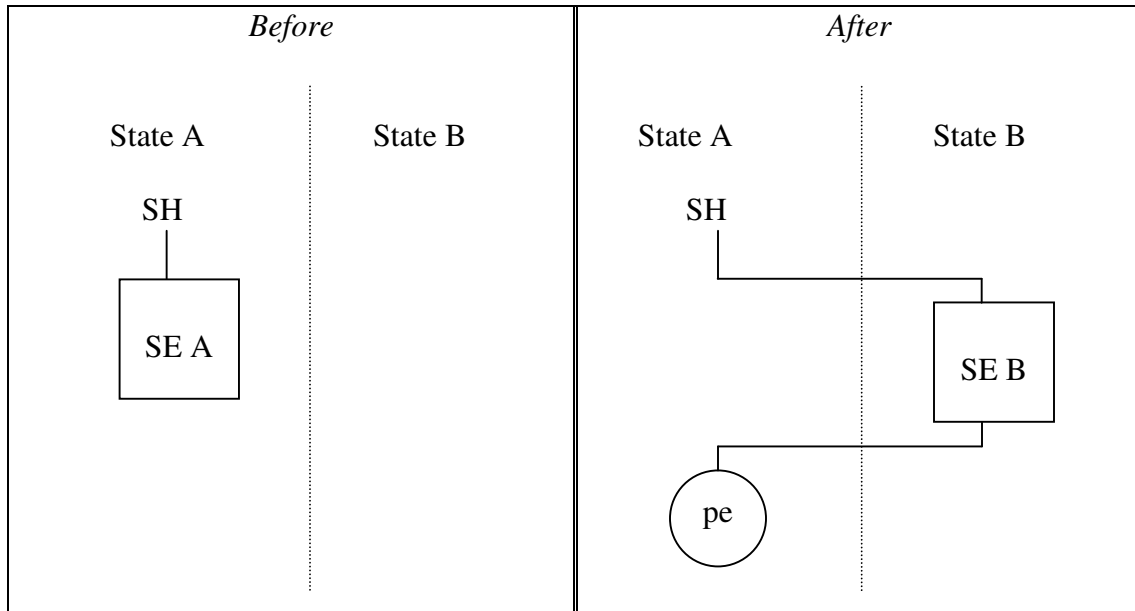

#### Facts and assumptions

- SE is an existing SE
- State A and State B are EU Member States
- SE A:
  - formed under the law of Member State A
  - registered office in Member State A
  - head office in Member State A
- SE B:
  - statutes are amended to conform to the law of Member State B
  - registered office in Member State B
  - head office in Member State B

#### Transactions

- registered office and head office of SE are transferred to Member State B (pursuant to Art. 8 Reg. 2157/2001 such a transfer shall not result in the winding up of SE or in the creation of a new legal person)

## Questions

- 1) Assume Member State A is Finland

### Tax effects of the transfer for SE

*Finnish tax law does not include special rules that could apply to a transfer of the registered office of an SE. Therefore, most likely is that such a transfer would be treated as if SE A had been wound up and as if a new company SE B had been established. In Finland the taxation of the company, which is liquidated is carried out as if the assets of the company would be transferred for a current price.<sup>108</sup>*

*It must be noted that if the property connected with the permanent establishment in Finland is transferred abroad, the transfer is treated as an alienation for Finnish tax purpose. The current value of the transferred property is then included in the taxable profits of the permanent establishment.<sup>109</sup>*

- a) Does the transfer entail a winding up of SE for tax purposes?

*This is the most likely result under the present domestic tax law rules.*

- b) What are the tax consequences in case of a winding up of SE?

*The taxation of the company that is liquidated is carried out as if the assets of the company would have been transferred for a current price.<sup>110</sup>*

- c) Does it make a difference whether or not a permanent establishments of SE B remains in Member State A?

*No difference.*

- d) If after the transfer of the registered office, SE B will have a permanent establishment in Member State A, can SE B take over the provisions and reserves which are partly or wholly exempt from tax with the same roll-over relief?

*No, because SE A was regarded to wind up for tax purposes and SE B is regarded to be a different company.*

- e) If after the transfer of the registered office, SE B will have a permanent establishment in Member State A, can SE B's permanent establishment in Member State A take over the losses of SE A that have not been exhausted for tax purposes?

---

<sup>108</sup> EVL § 51d and TVL § 27.

<sup>109</sup> EVL § 51e.

<sup>110</sup> EVL § 51d and TVL § 27.

*No, because SE A was regarded to wind up for tax purposes and SE B is regarded to be a different company.*

Tax effects of the transfer for SH

- f) What are the tax effects for SH in case the transfer results in a winding up of SE for tax purposes?

*As a consequence of the deemed liquidation of SE A, SH will be taxed as if he had received a capital gain corresponding to the difference between the current value and the acquisition cost of SE A.<sup>111</sup>*

- g) Is the answer to 1f) different if:
- i) SH is a corporate shareholder?  
*No difference.*
  - ii) SH is an individual shareholder?  
*No difference.*
  - iii) SH is an individual not owning a substantial interest?  
*No difference.*
  - iv) SH is an individual owning a substantial interest?  
*No difference.*
  - v) SH is an individual entrepreneur?  
*No difference.*
- h) Are there any effects for tax purposes if the transfer of the registered office is not considered as a winding up for tax purposes?

*If the transfer would not be considered as winding up of SE A for the Finnish tax purposes, there would be no direct tax consequences for the shareholder. However, the fact that the transfer would mean that the company would become a foreign company instead of a Finnish company would have effect for example on the tax treatment of the future dividend distributions.*

- i) Is the answer to 1h) different if:
- i) SH is a corporate shareholder?  
*No difference.*
  - ii) SH is an individual shareholder?  
*No difference.*
  - iii) SH is an individual not owning a substantial interest?  
*No difference.*
  - iv) SH is an individual owning a substantial interest?  
*No difference.*
  - v) SH is an individual entrepreneur?  
*No difference.*

---

<sup>111</sup> EVL § 51d and TVL § 27.

2) Assume Member State B is Finland

Tax effects of the transfer for SE

- a) If SE is considered to be a new company, how should the assets and liabilities of SE be valued?

*The assets and liabilities are valued at their current values.*

Tax effects of the transfer for SH

- b) Are there any tax effects for SH in case the transfer results in a formation of a new SE in your country? For example, with regard to the valuation of the shares in SEB?

*The shares will be valued for their current value.*

*Expected Amendments*

*Finally it must be noted that some major amendments are expected in the Finnish tax rules on for example corporate taxation and dividends after the spring 2003 elections. Some of the answers on the above questions may change as a result.*